

HF-150

COMMUNICATIONS RECEIVER

SMC



OPERATING MANUAL

South Midlands
Communications Ltd

Contents

Introduction	3
---------------------------	---

Getting started

Aerials	4
---------------	---

Active Antenna ...	
--------------------	--

Connections	7
-------------------	---

Types of signal	9
-----------------------	---

Controls

Front Panel	13
-------------------	----

Rear Panel	15
------------------	----

Operating the HF-150

Volume	17
--------------	----

Modes	18
-------------	----

Tuning	19
--------------	----

Keypad ..	
-----------	--

Aerial switch	22
---------------------	----

Memories	23
----------------	----

Accessory kit	24
----------------------------	----

Care of your receiver	25
------------------------------------	----

General notes	26
----------------------------	----

Technical information	27
------------------------------------	----

The term "Communications Receiver" was originally used in its quite literal sense to describe a radio receiver which was part of a point to point communications link. These radio links were normally manned by trained operators, and Morse Code was the usual method of transmitting information. Because of the specialist nature of the system and the fact that the operators were technically trained the communications receiver itself was quite often a complex piece of equipment.

Over the past twenty or so years, a marked change has taken place in short wave spectrum occupancy and there has been a considerable increase in broadcasting, air traffic control, news agency transmissions and so on. The interest in listening generated by this spread of activity has led to a demand amongst the general public for receivers which will enable them to keep in touch with world affairs by short wave radio.

Clearly, these users of receivers are more interested in listening than in the technicalities of operating the equipment and this in turn has resulted in the introduction of simpler receivers. However, simplicity of operation has often been accomplished by a compromise in actual performance, and the results obtained from some of these simple receivers have been quite disappointing. As our founder once remarked, "Some receivers are rather like a chocolate éclair; Wonderful to behold but containing little of substance."

The design and development of the HF-150 was based on straightforward objectives:-

- * To obtain sufficient RF performance for the receiver to operate in crowded short wave bands with many strong signals.
- * To combine complete control of a necessarily complex piece of equipment with easy operation for the user.
- * To achieve both the previous objectives within a compact, portable package at a reasonable price.

We believe that these stated goals have been reached, and that the HF-150 receiver represents a truly new approach to meeting the demands of the serious short wave listener.

Aerials and Earths.

Operating the HF-150 is described in the next two sections of this manual, but you may well ask "What is a suitable aerial?" The receiver has been designed to work well with a simple long wire aerial, about 10 to 30 metres long. This will provide good results on most frequencies covered by the set, but if your interest is in a particular band, such as the 49 metre broadcast band, you may wish to consider a dipole aerial tuned to that frequency. Do not be dazzled by the idea of putting up the longest wire in the whole world. This will bring you to grief, because you will probably overload the input stages of the receiver with signals from strong broadcast transmitters, with a resultant increase in background noise.

Where space is at a premium a short wire aerial (a few metres long, maybe indoors) or a whip aerial can be used. The HF-150 includes a whip antenna input circuit which optimises its performance with short aerials or in weak signal areas. However reception, particularly of lower frequencies (long and medium wave), will be compromised by a short aerial and the receiver will be more susceptible to locally generated interference.

A good aerial deserves a good earth connection and a ground system specifically for the receiver is always an advantage. This can be made fairly simply by driving a metal post into the ground to a depth of about 1 metre and connecting it to the black ground terminal on the rear panel of the receiver. With the exception of the 110V model, the mains power supply for the HF-150 provides an earth connection from the receiver to the mains earth system. This is often adequate for most locations, but in some situations can result in excessive interference from other mains appliances, which a separate earth system would avoid.

Long wire aerials should connect to the red terminal on the rear panel of the HF-150, whereas whips or short wire aerials should connect to the centre of the co-axial connector - a 4mm plug can be used to connect wires into this - and the antenna select switch set to the WHIP position. Any aerial systems that connect to the receiver by co-axial cable (active aerials and dipoles) should use the co-axial connector with the selector switch in the NORM position.

The Long wire Aerial.

This is the simplest type of outdoor aerial system, and is very effective for general short-wave listening. It consists of a single, insulated wire erected with a horizontal top section and a down lead from one end going to the receiver's wire aerial input terminal. The wire should be erected as high as possible, and as far away as possible from other structures or overhead power lines. It can often be suspended between two buildings or between a building and a tree. Insulators should be used as shown, and the lead in wire should also be insulated. The drawing shows a long wire with a 50ohm balun and a coax feeder, but many other configurations can be used, such as a slanting wire leading directly to the receiver.

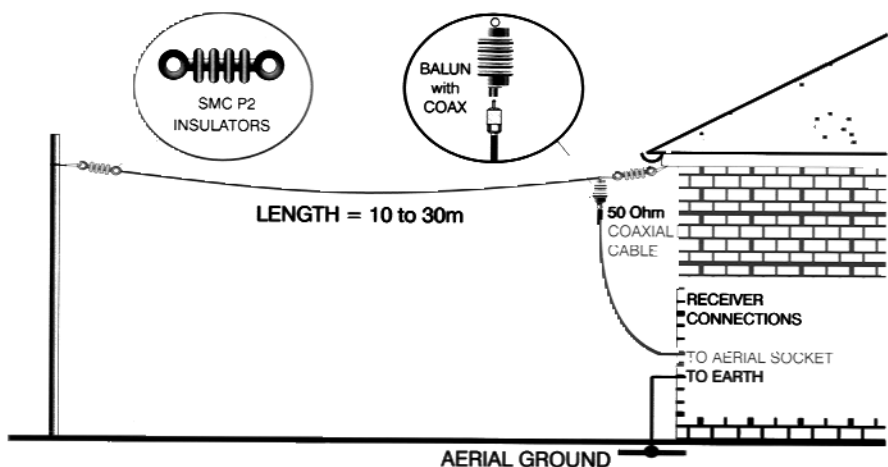

Other Aerials.

There are several ready-made vertical aerial systems on the market, and they will provide an easy to erect system occupying very little ground area. They are normally designed to work over quite a narrow frequency range (typically amateur radio bands), and for general listening a simple wire will often give better results.

Active aerials attempt to overcome the problems of very short aerials by placing a high-impedance amplifier between the antenna and the receiver. The amplifier must be near to the aerial, so often power is fed to it along the coaxial cable connecting it to the receiver. The active aerial is very compact, often little more than a metre long. Some are poorly designed and can badly compromise the receiver's performance due to the amplifier overloading in the presence of many strong broadcast signals. We strongly recommend the use of a high performance active antenna such as the AA-150M.

HF-150 MARINE RADIO

IMPORTANT

If you have purchased the Marine Radio version of the HF-150 you should be aware of the following.

The HF-150 is sent out for normal passive aerial use.

You can use this radio with an active aerial, which will require a 12V DC supply at the aerial socket.

To make the socket active.

- 1 Remove the four base fixing screws
- 2 Remove the bottom cover
- 3 Connect jumper to bridge the connector at the rear of the PCB.

WARNING: THIS WILL SUPPLY +12VDC TO THE AERIAL SOCKET AND THE JUMPER SHOULD BE REMOVED FOR NORMAL PASSIVE AERIAL USE

We strongly advise you to label the aerial socket clearly to inform users that 12VDC is present at this outlet.

South Midlands Communications Ltd will accept no responsibility or liability for the incorrect use of this feature.

If in doubt consult your dealer.

Suitable Active Aerial

The AA-150M optional accessory is a high performance active antenna which has been specially designed for the marine version of the HF-150(M).

This aerial has been carefully optimised to match the high performance of the HF-150M to prevent an overload of signal.

The modification details above will need to be set for use with this aerial.

Connections.

Power Supply.

The HF-150 receiver can operate from its internal batteries or from an external DC supply of between 10 and 15 volts. The absolute maximum supply is 16 volts, and if this is exceeded damage may occur to the receiver. The supply polarity is negative ground only, and although reverse polarity protection is built in it is wise to ensure that any supply is correctly connected. Be sure that the receiver power switch is OFF before plugging in or unplugging the power connector.

In most countries, the HF-150 will be supplied with a small 12 volt regulated power unit which is designed to operate from the local mains power. Remember that this supply will be operating all the time that it is connected to the mains outlet, and it is a wise safety precaution to disconnect it from the mains supply when the receiver is not in use.

The HF-150M marine receiver is supplied with a 12 volt lead only.

In the United Kingdom the power supply is fitted with a three-core mains lead, and the earth connection (yellow/green) is connected to the negative (ground) terminal of the receiver. This provides a reasonable earth connection for the receiver, but in some cases, where the mains-born interference is prominent, it will be necessary to provide the receiver with a good RF earth, either in addition to the mains earth or in some cases instead of it. If the receiver is used with any other mains power supply it should be able to comply with BSI standards relating to Class 2 insulation.

Either alkaline-manganese batteries or rechargeable nickel-cadmium batteries can be fitted to the receiver if it is to be used away from a source of power. Rechargeable batteries will charge within the set if it is connected to a 12 volt power source and switched off. For this reason we recommend that non-rechargeable ones are removed from the set if it is used for more than a few hours on an external supply.

Rechargeable batteries will run the set for three to four hours on a full charge, and require about 16 hours to charge fully from a 12 volt supply. Charging time can be longer than this without damaging batteries.

External Loudspeaker.

A small internal loudspeaker is provided in the HF-150 so that it is self contained, but although it can provide reasonable all round audio quality, clearly in the limited space available compromise has to be made. You will find that if the volume control is set to a high level there may be some audio feedback caused by vibration induced by the internal loudspeaker. If it is necessary to operate the receiver at high audio levels, or you want better quality reproduction the use of an external loudspeaker is recommended.

Because the HF-150 is capable of giving a high quality audio signal, we suggest you use a good external loudspeaker, a small bookshelf type Hi-Fi unit is satisfactory. We can provide a suitable unit as an optional accessory with the correct connecting lead for the HF-150. Any external loudspeaker should have an impedance of 4 ohms or greater.

Record Output.

Many keen listeners like to tape record any interesting stations they hear, and a low level audio output has been provided for this purpose.

The REC OUT socket accepts a 3.5mm mono jack plug and provides a level suitable for feeding into the line input of most tape recorders or amplifier systems. An attenuating resistor should be added in the lead if feeding directly into the microphone input of a cassette recorder. The output level at this socket is not affected by the volume control, so that the loudspeaker can be used to monitor whilst recording.

The record output can also be used for driving most types of receiver ancillary equipment such as RTTY, facsimile or Morse decoders. The output level is about 200m V from a source impedance of 5k ohms.

Types of Signal.

The HF-150 is equipped to receive most types of transmission likely to be found within its tuning range, and although most users will be familiar with these, here are some brief notes on this topic that may be useful to beginners.

AM (Amplitude Modulation).

This was the earliest method used of audio modulation of an RF carrier wave, and is still almost universally used for long, medium and short wave broadcasting. An AM signal is fairly easy to tune in, and given a reasonable signal strength, the receiver may not need to be spot on in frequency. However when conditions are poor, AM can be difficult to resolve - one particular problem is frequency selective fading and this is discussed later.

AM Selectivity.

A radio signal occupies a certain portion of the radio spectrum which is known as its bandwidth. The bandwidth of an AM signal is twice its highest modulation frequency, and because of this broadcasters are restricted to transmitting audio frequencies below 5kHz so that they do not occupy too much spectrum. In the long and medium wave broadcast bands, station frequencies are separated by 9kHz (10kHz in the USA) so there is little or no overlap of adjacent signal bandwidths. In the short wave bands however, the stations use a nominal 5kHz spacing, and some broadcasters do not abide by any rules at all, so there is considerable signal overlap.

The HF-150 is provided with two different AM modes with different filter bandwidths because of this very problem. If you are receiving a strong signal in a clear part of the radio spectrum then you can use the standard AM mode with a 7kHz filter and obtain the best fidelity. The stronger and closer adjacent stations are, the narrower the filter you will need, and the more muffled the sound will be because high frequencies are removed. The narrow AM mode uses a 2.5kHz filter and is necessary in severe conditions, but it is really only suitable for speech reproduction. When AM mode is chosen you may find that reception of a station is improved by tuning the receiver slightly above or below its stated carrier frequency. This is quite a useful technique if there is a strong adjacent signal that you don't want. As long as the carrier signal is within the receiver's filter then all will be well, but if you tune too far or select a narrower filter then the signal will become distorted.

SSB (Single Sideband).

An AM signal can be considered as a carrier wave combined with two identical sidebands which contain the modulating audio signal. It is possible to remove one of the sidebands without losing any vital information, and immediately halve the bandwidth occupied by the signal. In practice the carrier wave is also removed (or partially suppressed) to improve transmission efficiency, and the result is a single sideband transmission.

SSB transmissions are used extensively for voice communication, particularly to aircraft and shipping, and also by radio amateurs. It is possible to use either of the two initial sidebands of a signal, so there are two distinct types of SSB transmission; Upper Sideband (USB) where the sideband frequency is above the carrier frequency, and Lower Sideband (LSB) where it is below. Nearly all commercial transmissions are USB, as are amateur transmissions at frequencies above 10MHz. At frequencies below 10MHz radio amateurs use LSB by convention.

To receive an SSB transmission, the receiver must reinsert the missing carrier signal. If this is not done the signal will sound just like Donald Duck - try listening to an SSB signal in AM mode for this effect. For correct reception the receiver should be tuned exactly to the carrier frequency, but for speech an error of 50Hz either way will not be serious. The HF-150 has a very slow tune rate on its SSB modes to facilitate accurate tuning, but you will need a steady hand. The pitch of the received voice will change as you tune through the signal, but only at one tuning position will it sound like a natural voice. A 2.5kHz bandwidth filter will just accommodate the audio frequencies used for voice transmission, and this is the filter used for SSB reception.

CW (Continuous Wave, i.e. Morse).

Morse code is usually transmitted by interrupting a single carrier wave, and it occupies a very narrow bandwidth. In terms of ability to get a message through under difficult propagation conditions Morse code is one of the most efficient methods, although modern error-correcting digital data systems are also very good. CW signals are received in the same way as SSB signals, with the carrier inserted in the receiver producing a beat note with the incoming signal, and either the LSB or USB modes can be used. Often the one chosen is a matter of operator preference, or one which best rejects any interfering signals.

RTTY (Radio Teletype).

The method of sending teleprinter messages by HF radio link is to use two closely spaced tone signals, transmitting one or the other to send binary data. Each teleprinter character is encoded into a different sequence of tones which are transmitted in a bewildering combination of different speeds, tone shifts, and code types. RTTY signals are tuned in SSB mode on a receiver, but require a special terminal unit to decode and display the actual text.

FAX (Facsimile).

Pictorial information (often meteorological data) is transmitted over HF radio links for reception by shipping. As with RTTY, a special facsimile decoder and display or printer is required for its reception. Several home computers support software packages for decoding FAX and RTTY signals.

FM (Frequency Modulation).

FM transmissions in the HF spectrum are usually limited to the 27MHz Citizens Band and the 28MHz amateur band. The HF-150 does not offer an FM mode to directly receive these signals, but it is usually possible to resolve them in AM mode with the receiver off-tuned by some 3kHz above or below the transmission frequency. This is technically known as 'filter slope detection'.

AM Propagation and Fading.

During AM signal reception it is possible to experience severe fading problems, particularly after nightfall. This is mainly due to the signal reaching the receiver by several different paths from the transmitter, and it is most common after dark because this is when the ionosphere reflects most HF radio signals. Fading occurs when the signals arrive at the receiver in antiphase (having travelled different distances) and then cancel each other out. This will only occur at a few specific frequencies at any one instant, hence the term frequency selective fading.

If a selective fade reduces the carrier level of an AM signal, but leaves the sideband levels unaltered, a receiver with a conventional AM detector will not be able to correctly reproduce the signal, and the output will be distorted. There are two techniques that can be used to improve the situation; ECSS, and Synchronous (or Phase-Locked) AM detection.

ECSS (Exalted Carrier, Selectable Sideband).

The ECSS technique makes use of the fact that with a good, selective receiver, capable of resolving SSB, an AM signal can be passed through the SSB filter which is only wide enough to allow one sideband through. The filter must attenuate the carrier signal by at least 20dB for this technique to work with any success.

The receiver can be used in the SSB mode with the incoming AM carrier tuned to zero beat, and the accompanying sideband treated as a true SSB signal. Either the upper or lower sideband can be selected using either USB or LSB mode, so interfering stations can often be eliminated. The improvement in intelligibility is often dramatic, and it is well worth trying out ECSS and developing the ability to use it. The HF-150 when used with its USB or LSB modes is ideally suited to ECSS reception.

AMS (Synchronous AM)

The difficulty in receiving music signals with the ECSS method is that it is very difficult to match the receivers injected carrier exactly with the frequency of the incoming carrier. Any difference results in a frequency shift of the audio signal, and the consequent loss of harmonic relationships.

The synchronous AM detector in the HF-150 uses a narrow deviation phase-locked oscillator to replace the incoming AM carrier. When locked, this oscillator is at exactly the same frequency as the carrier signal, and does not have to rely on absolute receiver tuning accuracy. Incoming carrier level changes make no difference to the signal detection provided that there is some carrier for the oscillator to lock on to.

A total of four filter arrangements are available on the HF-150 in synchronous AM mode: - upper sideband only, lower sideband only, both sidebands (for better resistance to fading if there are no interfering signals) and a special "Hi-Fi" mode which gives extended frequency response and very low distortion for listening to clear, strong stations.

Front Panel Controls.

1) **Memory mode flag:** This segment of the display is shown when the receiver is in memory mode. The keypad and tuning knob select memory numbers, and the three control buttons operate as **MEMORY**, **RECALL** and **STORE**.

2) **Frequency display:** The 5-digit liquid crystal display normally shows the receiver's tuned frequency, with a decimal point in between megahertz and kilohertz sections. At frequencies below 1.7MHz, (i.e. medium and long wavebands) the display shows kilohertz with no decimal point. Additionally the display is used to indicate mode and memory number when appropriate control buttons are pressed.

3) **Tuning knob:** For tuning the receiver and selecting memories. The rate of tuning is altered according to the receiver's mode and the speed of rotation of the tuning knob. Memory numbers are changed by turning the tuning knob when the receiver is in memory mode.

-
- 4) **Volume control:** Combined with the on/off switch, the volume control operates for the internal and external loudspeakers and the headphone output. The record out jack is unaffected by the volume setting. The on/off switch controls receiver power and battery charging if NiCd batteries are fitted.
- 5) **Headphone jack:** An output for use with personal headphones - the receiver's internal speaker is disconnected when headphones are plugged in. A 6.3mm mono or stereo plug is suitable for the headphone output, and 'phones fitted with a 3.5mm plug can be used with a suitable adapter. Stereo headphones will operate in mono.
- 6) **Memory button:** Pressing the MEM button changes the receiver between memory and tuning modes. In memory mode the memory flag (1) is shown and the tuning knob and keypad select memory numbers. When in memory mode, pressing MEM, RCL or STO will revert to tuning mode.
- 7) **Mode button:** The MODE button operates when the receiver is in tuning mode, and allows selection of the type of reception. The display shows a mnemonic representing each mode, and the other two buttons can be used to step forwards or backwards through the eight available modes. See page 15 "Modes". Reception changes as soon as a new mode is selected. The display will revert to frequency when MODE is pressed a second time, or after about 7 seconds without any buttons being pressed, or if the tuning knob is rotated.
- 8) **Fast tune button:** If the receiver is in tuning mode, pressing the FAST button speeds up the tuning rate of the main tuning knob. The two right-hand display digits are blanked, and the display is altered in 100kHz steps. The receiver is tuned to the newly selected frequency when the FAST button is pressed again.

Rear Panel Controls and Connections.

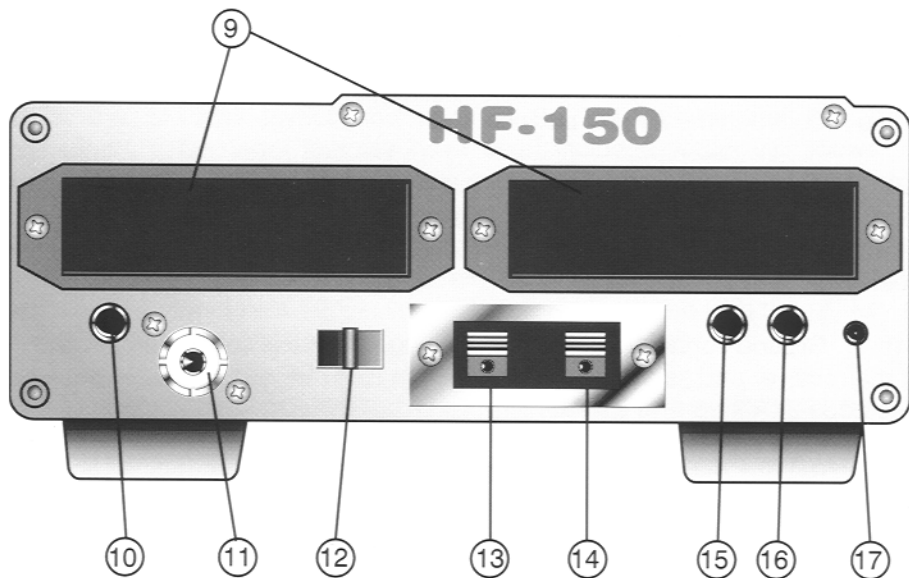

9) **Battery holders:** The HF-150 needs a total of eight AA size batteries to operate - 4 cells in each of the two battery holders. The Battery drawers are released by squeezing together the lugs on either side of the holder. When replacing a drawer make sure that it is pressed fully in so that the cells are suitable, but all eight cells must be of the same type. Standard zinc/carbon cells are not recommended because of the risk of leakage.

Nickel/cadmium cells will recharge in the receiver provided that it is connected to a 12volt supply and the volume/power switch is in the OFF position. Non-rechargeable cells should be removed from the receiver if it is connected to an external supply for more than a few hours.

10) **Keypad jack:** For connection of the optional keypad unit, allowing direct entry of frequencies and memory numbers.

11) **Coaxial/Whip aerial connection:** This SO-239 type connector provides the receiver input from aerials terminated with coaxial cable (nominally 50 ohms impedance) or for the whip aerial supplied in the accessory kit. The select switch (12) determines the function of this socket.

12) Aerial select switch: This three-position switch controls the operation of the whip aerial amplifier and the RF attenuator. In the WHIP position the SO-239 socket (11) is intended for a whip aerial or a short wire (just a few metres) and the spring terminal (13) is disconnected. In the NORM and ATTEN positions both aerial input are operative, with signal strengths reaching the receiver being reduced in the ATTEN position.

13) Wire aerial connection: The red spring terminal is for connection of long wire aerials and has a nominal impedance of 600 ohms. This input is disconnected from the receiver when the aerial select switch (12) is in the WHIP position.

14) Ground connection: The black spring terminal is connected to the case of the receiver and serves as the connection to an RF earth if this is provided. See page 3 "Aerials and Earths".

15) Record output jack: A fixed level audio signal is available from this socket that is unaffected by the volume control setting. The level (about 200mV) is suitable for feeding into the line input of most tape recorders and for driving FAX, RTTY, etc decoders. If the signal has to be fed into the microphone input of a tape recorder (in the absence of a line input) then a series resistor should be inserted in the connection to reduce the signal level.

16) External loudspeaker jack: For connection of an external loudspeaker of 4 to 8 ohms impedance. Inserting a plug into this jack will disconnect the internal loudspeaker, and this output is disconnected by insertion of a plug into the front-panel headphone jack.

17) Power input connection: An external DC power supply is connected here if the set is not to run on its internal batteries. If you are not using the supplied mains adapter then check that the supply polarity is correct (positive-inner, negative-outer) and that the voltage is between 10 and 15 volts. Current requirement is about 120mA rising to 300mA at high volume settings.

Operating the Receiver.

Volume/Power.

The volume control affects the level of the sound from the loudspeaker or fed to the headphones. The signal from the record out socket on the rear of the receiver is not altered. It also functions as a power switch, and turning it fully counter-clockwise will turn the receiver off. If you are running the receiver from its mains adapter then the adapter will still be powered even if the receiver is turned off, and you should switch off or unplug the adapter when not in use.

If rechargeable batteries are fitted to the HF-150 then they will charge if power is supplied to the receiver when it is switched off. The batteries will fully charge in about 16 hours from a completely discharged condition. A limited amount of over-charging will not harm the batteries, but you should avoid charging for periods longer than 3 days. When the receiver is switched on, a small trickle-charge is supplied to the batteries which will maintain a full charge against gradual leakage.

When running the receiver from batteries, a message LoPr (low power) will be shown when the battery voltage falls below a usable level. The tuning and push-button controls will stop operating but the receiver may still work for a few minutes. Replace the batteries or run the receiver from an external supply to restore normal operation. It is common for the low power message to display momentarily when the receiver is switched off.

Modes.

There are three types of reception available on the HF-150: - Single sideband, AM and Synchronous AM (AMS). The eight modes selectable on the receiver choose various filter combinations within these three types. Mode selection is made by pressing the MODE button on the front panel of the receiver and then using the other two buttons to step backwards or forwards through a choice of modes, shown by mnemonics on the display. When a mode has been selected, it will remain displayed, and can be further changed, for about 7 seconds before the display reverts to frequency. Pressing the MODE button or turning the tuning knob during this period will immediately cause the display to revert to frequency. The mode selection sequence is shown over the page.

Type	Display	Mode	Filter Bandwidth
SSB	LSb	Lower sideband	2.5kHz
	Usb	Upper sideband	2.5kHz
AM	A	AM, wide filter	7kHz
	An	AM, narrow filter	2.5kHz
AM Sync	ASd	AMS, double sideband	7kHz
	ASF	AMS, "hi-fi" mode	7kHz
	ASL	AMS, lower sideband only	2.5kHz
	ASu	AMS, upper sideband only	2.5kHz

Forward selection sequence (right-hand button) :-

LSb -> Usb -> A -> An -> ASd -> ASF -> ASL -> ASu -> LSB etc.

Backward selection sequence (left-hand button) :-

LSb < - Usb < - A < - An < - ASd < - ASF < - ASL < - ASu < - LSB

Tuning.

The HF-150 is tuned with a single rotary control (which drives a digital shaft encoder) giving continuous tuning over the whole of the receiver's range. There are no separate tuning bands on the HF-150, but for convenience a fast tune mode is provided to tune in 100 kilohertz steps to a frequency near the one of interest.

The frequency readout on the HF-150 is at the true carrier frequency in all modes of reception. It is at the centre of the filter passband in AM mode, and at the reinjected carrier frequency in USB and LSB modes. Although the frequency display mode changes in 1 kilohertz steps the receiver is actually tuned in much smaller steps - sufficiently small for tuning to appear continuous.

The rate at which the receiver tunes when the tuning knob is rotated depends on the mode selected and on the speed of rotation of the knob. When the tuning knob is rotated rapidly the tuning rate increases. This allows a slow tuning rate for precise signal resolution coupled with the ability to reach the required frequency quickly. You may find at first that the receiver apparently jumps in frequency when you are trying to tune a signal. This is because you have moved the tuning control quickly or in a jerky fashion and the receiver has increased its tuning rate. A smooth action will cure the problem, and will make tuning the HF-150, and any other receiver, much easier.

The tuning rates adopted by the HF-150 are shown in the table below: -

Mode	Normal tune rate		Fast tune rate
	Tuning step	kHz per rev	
LSB, USB	8Hz	1.6	8 times faster
AM, AMn	60Hz	12	6 times faster
AMSd, AMSf	8Hz	1.6	Switches to AM
AMS1, AMSu	8Hz	0.8	Switches to AM

When the operating frequency limits of the HF-150 are reached, tuning will stop. There are no mechanical stops on the tuning knob, but you will notice that the frequency display stops changing. The lower tuning limit is 30kHz and the upper limit 29.999MHz on a standard model, but these are changed to 150kHz and 29.999MHz for the German market. Unlike some receivers, the HF-150 does not wrap-around between its highest and lowest frequencies.

Fast Tuning Mode.

Pressing the FAST button blanks the two rightmost digits of the frequency display and allows the tuning knob to rapidly change the remaining three digits. The receiver remains tuned to its previous frequency during this operation, but is tuned to the new frequency when the FAST button is pressed a second time.

The frequency set by the fast tune mode retains the setting of the blanked digits from the previous receiver frequency, so an inadvertent press of the FAST button can be cancelled by simply pressing the button again without turning the tuning knob.

Tuning in Synchronous AM Mode.

The tuning of the receiver in synchronous AM mode is more critical than in the normal AM modes, because the signal has to be within the lock range of the synchronous detector. To aid tuning, a slow tuning rate is provided in all four AMS modes. It is difficult to 'search tune' in AMS mode (i.e. tune through a selection of frequencies looking for a particular signal) so the receiver automatically switches to normal AM mode whenever the tuning knob is rotated quickly. When the tuning knob is not moved for about one second the receiver will return to its previous AMS mode.

When switched to an AMS mode, if the receiver is not exactly tuned then the received signal will be heard with a superimposed tone. Slowly turn the tuning knob so that the pitch of the tone falls, and continue until the tone stops. If you continue turning the tuning knob the tone will start again and rise in pitch. The optimum tuning position lies halfway between the points at which the tone stops and restarts. Rock the tuning knob backwards and forwards to find this point - it should give best clarity of reception and minimum background noise. During severe carrier fading it is possible for the detector to unlock from the signal, causing a tearing sound. This effect can often be minimised by some judicious fine tuning.

For general listening the ASd mode is recommended as giving the best compromise between signal clarity and rejection of nearby stations. If the signal you are listening to is strong and not subject to interference then the ASF mode will give a wider frequency response (more treble). If, however, you are listening to a signal in a crowded band then the ASL and ASu modes will offer the best rejection of adjacent stations - try both to see which is best for the current conditions.

Keypad frequency entry.

If you plug-in the optional remote keypad then you can tune the receiver by entering frequencies directly. This is very useful for quickly checking stations at known frequencies, or for setting the frequency in a particular band of interest and then searching for signals with the main tuning knob. The keypad is separate from the receiver so that it can be positioned alongside for convenient use. It is connected by a short cable which should be plugged into the KEYPAD jack on the rear panel of the HF-150. The keypad has 12 keys - the digits [0] to [9], the [#] key (enter), and the [*] key (cancel). As keys are pressed the digits are shown on the receiver's frequency display.

Frequencies are entered in kilohertz. The receiver will only tune to the entered frequency when it is complete - either when sufficient digits have been keyed in or when the enter key [#] is pressed. Frequencies above 3000kHz will enter automatically as soon as the last digit is keyed. Those below 3000kHz should be followed by the enter key [#].

For example	[1]	[2]	[0]	[9]	[5]	tunes to 12.095MHz
	[1]	[9]	[8]	[#]		tunes to 198kHz

Supplement to 'Keypad Frequency Entry'

The Keypad is now being replaced with a re-designed internal configuration which employs a small micro controller to decode the keys and output the data.

Whilst the physical layout and style of the popular keypad has been maintained, a few extra features have been included which still allows the keypad to be used with previous Lowe receivers i.e. HF125/HF225.

The frequency entry remains unchanged, with frequencies of 3000KHz and above being automatically selected as the the last digit is entered on the keypad. Frequencies of 2999KHz and below are selected with the '#' key as the last digit.

HF-150 users may also access the different modes in any order by holding down the '*' key and then using any of the numbers 1-8 as indicated by the keypad diagram below.

Keypad 2 layout showing function key selection

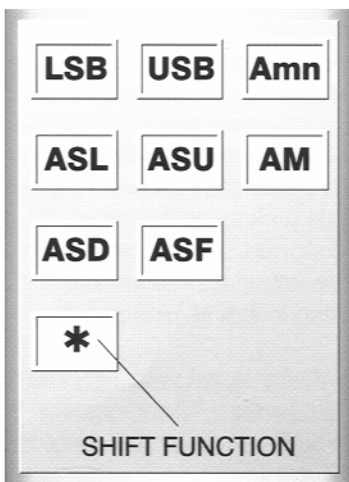

Because frequencies entered by the keypad are to the nearest kilohertz, it may be necessary to retune the receiver slightly to correctly resolve single sideband signals or when using the receiver in AMS mode.

If you press an incorrect key on the keypad, the current digits can be cleared by pressing the cancel key [*], after which the frequency should be re-entered. Please note that once keypad frequency is started the other controls on the receiver will be inoperative until entry is completed or cancelled.

There is a quick access to frequencies stored in the receiver's memories. If a number between 1 and 60 is keyed in, followed by the enter key [#] then the appropriate memory is recalled and the receiver's mode and frequency set. See page 20 for full details of memory operation. To key in a frequency below 60kHz, prefix the number with a zero.

For example	[2]	[#]		recalls and tunes memory 2
	[4]	[5]	[#]	recalls and tunes memory 45
	[0]	[4]	[5]	[#] tunes to 45kHz

Aerial Select Switch.

The aerial switch on the rear panel controls the function of the two aerial sockets. Both the wire aerial terminal and the 50 ohm socket are active with the switch in the NORM and ATTEN positions, but only the whip socket will work with the switch in the WHIP position.

The RF attenuator inserted in the aerial circuit with the switch in the ATTEN position reduces the signal that reaches the input stages of the receiver. There are two situations where its use is beneficial, firstly when a strong local signal exceeds the range of the automatic gain control in the receiver, and secondly when strong, unwanted signals picked up by the aerial overload the receiver's input. If reception becomes distorted or background noise becomes unusually high then try switching in the attenuator and see if the situation improves, otherwise leave the aerial switch in the NORM position.

The WHIP position should only be used with whip aerials or very short wire aerials connected to the whip socket. The receiver's input stage is likely to overload and degrade reception if a substantial aerial is used.

Memories.

The HF-150 has 60 memories which can store receiver frequency and mode settings. Memory information is saved in an EEPROM device within the receiver which needs no power to retain its information. There are three memory functions - preview, recall and store - controlled by the buttons on the front of the receiver:-

Pressing MEM will show the memory mode flag in the display with a two-digit memory number (01 to 60). After about one second the display will change to the frequency stored in that particular memory. This is the memory preview function. Turning the main tuning knob will display the memory number again and select different memories to preview. The receiver's tuned frequency is not affected whilst previewing memories, and the memory mode flag in the display indicates that the main tuning knob selects memories rather than tuning the receiver.

After selecting and previewing a memory you can use the store or recall functions. Pressing RCL retunes the receiver to the frequency and mode in the selected memory and returns the display to received frequency. If you tune the receiver now, the contents of the memory will not be affected. Pressing the STO button will save the current tuned frequency and mode in the selected memory, over-writing its previous contents. A message STo appears briefly on the display to confirm operation. Pressing MEM will return the receiver to normal tuning mode, with the received frequency on the display.

If a keypad is plugged into your receiver, then the memories can be selected by keying in the required number directly. With the memory mode flag shown on the display a two-digit memory number can be keyed in, and the receiver will then preview this memory. Note that you must key in two digits, so, for example, press [0] and [5] to select memory number 5. The cancel key [*] will clear an incorrectly entered first digit, and the enter key [#] operates in the same way as the front panel RCL button.

Accessory Kit.

The accessory kit, AK-150, contains all the items necessary to operate the HF-150 as a portable receiver - carrying handle, whip aerial and rechargeable batteries. In detail the contents are: -

- 1 Telescopic whip aerial, 1.2m long, screw fitting.
- 8 AA-size nickel-cadmium batteries.
- 2 Brackets for carrying handle or shoulder strap.
- 1 Carrying handle.
- 1 Adjustable shoulder strap with shoulder pad and wire aerial.
- 4 Adhesive feet.
- 1 2.5mm Hexagon wrench.

Fitting the Handles.

The metal handle brackets fasten to the HF-150 using the main panel fixing screws at the front and back of the receiver. The supplied hexagon wrench can be used to undo and replace these screws.

The short carrying handle can fasten to the left-hand or right-hand side of the receiver. Undo two screws to fix one bracket at a time, thread the bracket through the loop at the end of the handle strap and then fix the bracket with the two screws. Repeat this procedure for the bracket at the other end of the handle. Do not over-tighten the screws - only gentle finger pressure is required. You can stick the four adhesive feet on to the opposite side of the receiver from the handle if you wish.

The shoulder strap fixes in the same way as the short handle, but can additionally be fixed to each side at the front of the receiver, so that the set hangs on its strap with controls upwards. If you want to use the wire aerial in the strap, fitting on the right-hand side of the receiver is recommended, and the plug on the aerial wire should be inserted in the centre of the whip socket. The length of the wire between the strap and the plug can be adjusted by sliding the wire up and down the strap. It is fixed at the top by a folded-back loop and can be removed if not required.

Care of your Receiver.

The HF-150 is a complex piece of electronic equipment, and it makes good sense to look after it. Install it in a well ventilated place, out of direct sunlight and as free from dust as possible. Use a damp cloth and soap or a mild detergent to clean the exterior of the receiver. Do not use abrasive cleaners or solvents. The front panel legends are printed on the reverse side of the plastic panel so they won't wear off in use, the rear panel legend is anodised into the aluminium.

Obviously you should avoid spilling your coffee over the HF-150, and it won't last long if you leave it out in the rain. In other words keep the receiver dry. It is intended to work at normal domestic room temperatures, and hot or cold extremes of temperature may affect its proper function.

Please make sure that the various sockets on the HF-150 are used for the intended purpose. It is no use plugging the extension speaker into the keypad socket, or trying to connect the antenna input to the live side of the mains power. The likely result will be tears of distress and a big repair bill. The HF-150 is powered by 12 Volts DC, negative ground only. BE CAREFUL when applying power from any source other than the power unit provided with the receiver. Remember to disconnect the power supply from the mains when it is not in use.

If there is an electrical storm in the vicinity of your house it is sensible to switch off the receiver and disconnect any external aerial system from it, since potentially damaging voltages can be induced in a large aerial.

Finally, after unpacking your HF-150, please retain the carton and packing material. If you should ever need to transport the receiver it will survive the journey much better in the correct carton.

General Notes.

If there is a momentary power failure, or if you plug in the power connector whilst the receiver is switched on, you may find that the receiver does not receive, or fails to respond to its controls. The problem is caused by the microprocessor controller having "crashed." The fault can be rectified by switching the receiver off, waiting a few seconds, and then switching it on again - all should be well, but occasionally the frequency information in the memories may be garbled.

In the same way that high volume levels from the internal loudspeaker may cause microphonic effects, external shock or vibration can cause frequency fluctuations. Of course it is not normal to bang the receiver around.....

Strange effects can also occur if the receiver is placed in a strong alternating magnetic field, for example in close proximity to a large mains transformer in another piece of equipment.

When tuning the HF-150 you will notice that the output will be muted for about half a second as you tune through the local oscillator range switching frequency at 11.576MHz. This is quite normal and should not be taken as a fault. Also one other effect that you may notice when tuning the receiver in some parts of the band is a whining noise as the tuning control is rotated. It is caused by the data transfers inside the receiver being picked-up by the input circuitry and it is normally not audible above the noise and signals coming from the aerial connected to the receiver.

As in any receiver there are a few spurious signals generated internally, mostly at or slightly above the background noise level of the receiver. Again these signals are usually masked by aerial noise and rarely cause any degradation to reception of radio signals.

Technical Information.**Specification.**

Frequency coverage	30kHz or 150kHz to 30MHz continuous coverage. (depending on region)
Reception modes	LSB, USB, AM, Synchronous AM (USB, LSB, DSB)
Receiver system	Microprocessor controlled PLL tuning, dual conversion superheterodyne receiver. First IF 44.999MHz to 45.000MHz, second IF 455kHz.
Display	5-digit LCD showing frequency to the nearest kilohertz, receiver mode and memory numbers.
Tuning	By Spin-wheel, and direct key frequency entry (option).
Tuning steps	8Hz in LSB, USB and AMS modes, 60Hz in AM mode. Step size increases with rapid spin-wheel rotation. Keypad frequency entry is to 1kHz resolution.
Memories	60 memories holding frequency and mode. Memory functions: - Preview, Recall, Store. Data held in EEPROM for > 10 years. Tuned frequency is saved when receiver is switched off.
Aerial inputs	50 ohm input via SO-239 socket. 600 ohm input and earth connection on press terminals. High-impedance active aerial for whip via SO-239.
R F attenuator	20dB
I F filters	Wide: 7kHz, narrow: 2.5kHz
Audio outputs	Record output at approx. 200mV (3.5mm jack). External loudspeaker (3.5mm jack). Headphone output (mono or stereo) (6.3mm jack). The internal loudspeaker is disconnected when headphones or external loudspeaker are plugged in.

Power supply	12V DC supply @ 130 to 300mA (2.1mm power jack). 240V AC Mains powered unit supplied as standard. Internal batteries - 8 AA-size cells. (Charging circuit included for NiCd cells).	
Dimensions	Size 185 x 80 x 175mm (WxHxD, overall). Weight approx 1.3kg (1.5kg with batteries).	
Options	KPAD-2	Plug-in numeric keypad for direct frequency entry.
	AK-150	Accessory kit for portable operation: - Whip aerial. Rechargeable batteries. Carrying handle. Shoulder strap.
	AA-150M	Active Antenna
	PS-12A	Power Supply - 240Volt
	PS-12A/110	Power Supply -110Volt

Performance.

Sensitivity	Into 50 ohm aerial input, for 10dB signal/noise ratio. AM signal - modulated to 70% depth at 1kHz. <2uV 50kHz to 500kHz <1uV 500kHz to 30MHz <0.3uV 500KHZ to 30MHZ with whip amplifier. SSB signal - unmodulated, resolved at 1kHz. <1uV 50kHz to 500kHz <0.5uV 500kHz to 30MHz <0.2uV 500kHz to 30MHz with whip amplifier.
Selectivity	Narrow filter - 2.6kHz @ -6dB, 4.1kHz @ -60dB Wide filter - 6.5kHz @ -6dB, 10.2kHz @ -60dB
Dynamic range	Reciprocal mixing: (narrow filter) 75dB @ 5kHz, 85dB @ 10kHz, 100dB @ 50kHz Third order intermodulation: (narrow filter) 90dB @ 50kHz, intercept point +7dBm 87dB @ 20kHz, intercept point +4dBm 70dB @ 10kHz, intercept point -20dBm

Spurious responses	>65dB rejection of images, IFs, etc.
Frequency stability	(Typical performance only) At constant 20C Drift <30Hz/hour, error <50Hz. -10C to + 50C Error <200Hz.
Audio output	1.6W into 8 ohms at 5% THD. (With 12V PSU). 2.0W into 4 ohms at 5% THD. Headphone: up to 4V from 220 ohms. Record output: 150 to 200m V from 5k ohms.
Frequency response	SSB mode: 170Hz to 2.8kHz @ -6dB AM mode: 30Hz to 3.3kHz @ -6dB ASF mode: 20Hz to 5.5kHz @ -6dB
Distortion	<1% THD all modes.
AMS Detector	Lock range: DSB +/- 100Hz, SSB +/- 50Hz.

Specification subject to change without notice.

Circuit Description.

The HF-150 is a dual conversion superheterodyne receiver, using up-conversion to a high frequency first IF of 45MHz and a second IF of 455kHz for the selective filters. This design gives good IF image rejection at all tuned frequencies in the HF band, coupled with good filter shape factors in the 455kHz IF.

Signals from the aerial pass through a 30MHz low pass filter before the first mixer - a fully balanced device to reduce even-order intermodulation distortion. The filter removes signals that may interfere at the IF or image frequencies. Unless the whip amplifier is switched in there is no RF stage before the first mixer, and this, coupled with the use of a high performance transistor-tree mixer, gives the HF-150 a high dynamic range and good resistance to strong signal overload. A crystal filter with a 15kHz bandwidth in the first IF (at 45MHz) limits the signals fed to the second mixer and removes image responses from the second IF.

Most gain in the receiver is in the 455kHz second IF stage, where amplifiers and filters are interspersed in a chain.

The receiver uses ceramic multi-element filters in this IF - a total of three filters giving very good skirt selectivity. At the end of the second IF, a full-wave envelope detector serves as a low-distortion AM detector and an AGC source.

The AGC system incorporates a noise spike suppressor to stop static crashes momentarily "deafening" the receiver.

The IF signal also feeds a product detector which is used for detection in SSB and AMS modes, when the IF is mixed with a digitally generated carrier signal.

A separate limiting IF amplifier and mixer provide the frequency correction signal for AMS detection. This signal is used to fine-tune the IF conversion oscillator when AMS mode is selected.

Receiver tuning is achieved by varying the frequency of both the local oscillator and the IF conversion (heterodyne) oscillator. The local oscillator covers 45.030MHz to 74.999MHz in 1kHz steps, and fine tuning is provided by the heterodyne oscillator covering 44.544MHz to 44.545MHz in 128 steps. The final carrier insertion frequency is determined by the mode selected so that the IF filter passband is in the correct position relative to the carrier for USB or LSB reception. A numerical offset is calculated in the controlling microprocessor so that the frequency display reads the received carrier frequency correctly even when the intermediate frequency is offset.

Only the local oscillator signal is produced by a phase-locked-loop frequency synthesiser, but all frequencies affecting the tuning of the receiver are crystal derived to ensure good frequency accuracy and low drift in operation.

All the switching and tuning functions in the receiver are under the control of a dedicated microprocessor system, which receives commands from the front panel controls and sends information to the various receiver stages and the PLL system on serial data busses. The single-chip microprocessor is supported by a controller driving the liquid crystal display and a frequency memory chip which is an EEPROM. All these components are mounted separately from the main RF and IF circuits on a PCB behind the front panel.

The control system is designed to use the "static idle" principle, whereby there are no signals (other than reference/clock oscillator) in the system until the operator requires a change in the receiver condition. The system then reacts to commands from the receiver's controls before returning to its static condition once again. This method of operation virtually eliminates spurious signals from the control system before being picked up by the receiver's input stages.

HF -150 CONTROL UNIT

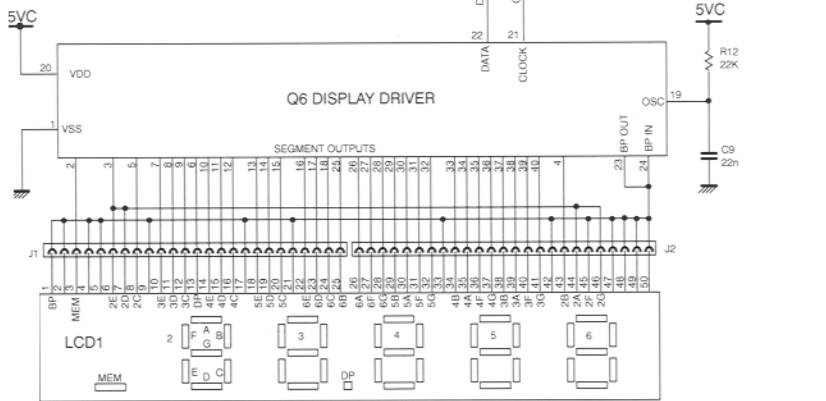
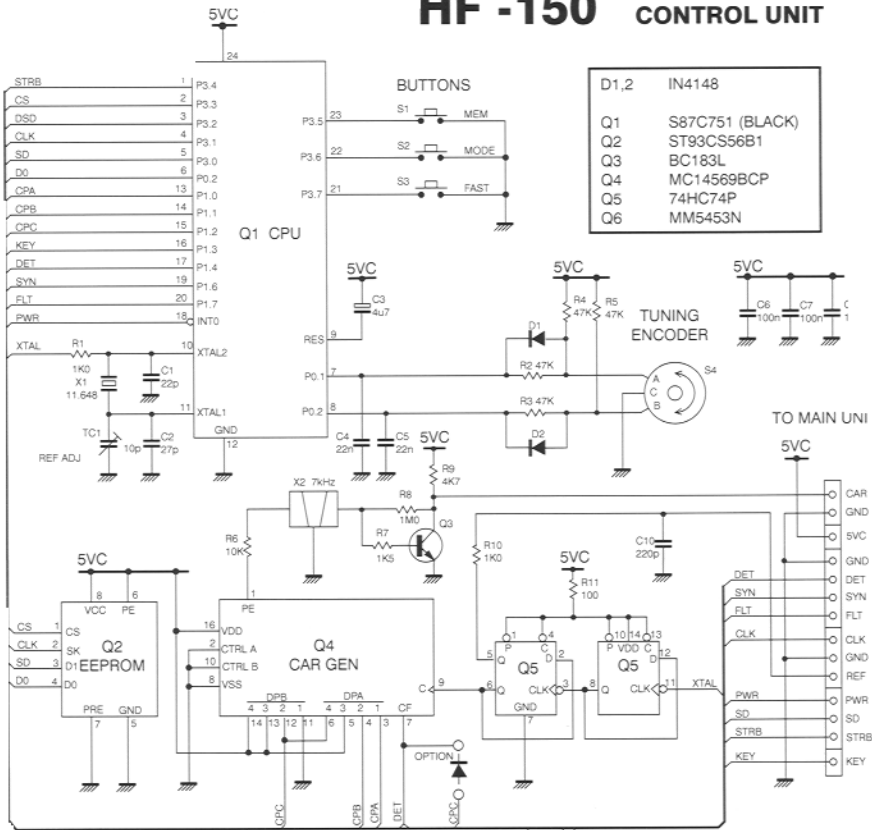

HF-150 MAIN UNIT

RF and IF SECTION

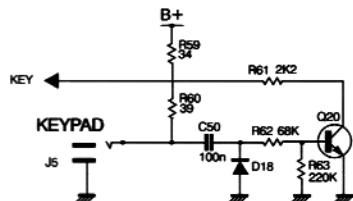

Q19	J310	Q27	MC3357P
Q20,21	BC183L	Q28-31	BC183L
Q22,23	SL6440CDP	Q32	SL6700CDP
Q24	ZTX320		
Q25	TDA1904	D17	MI204
Q26	74HC02	D18-28	IN4148

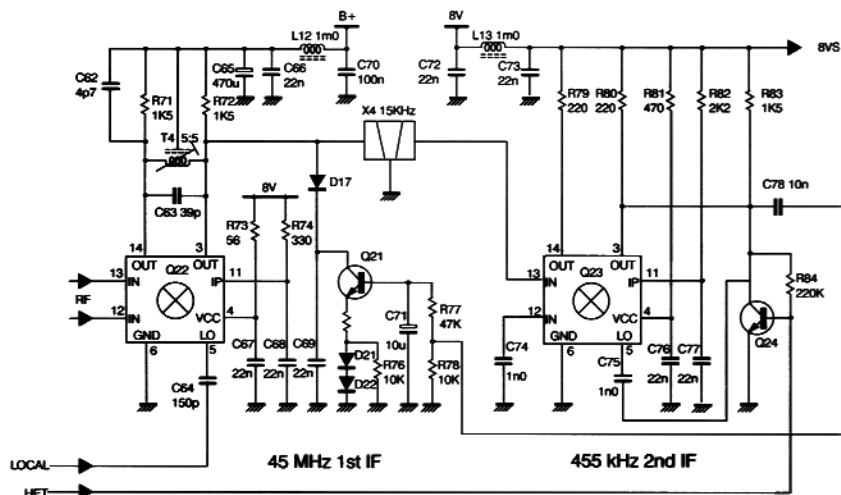
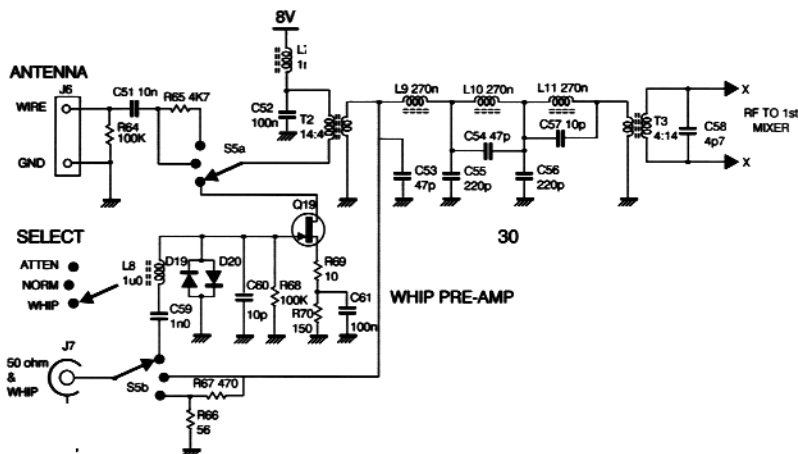

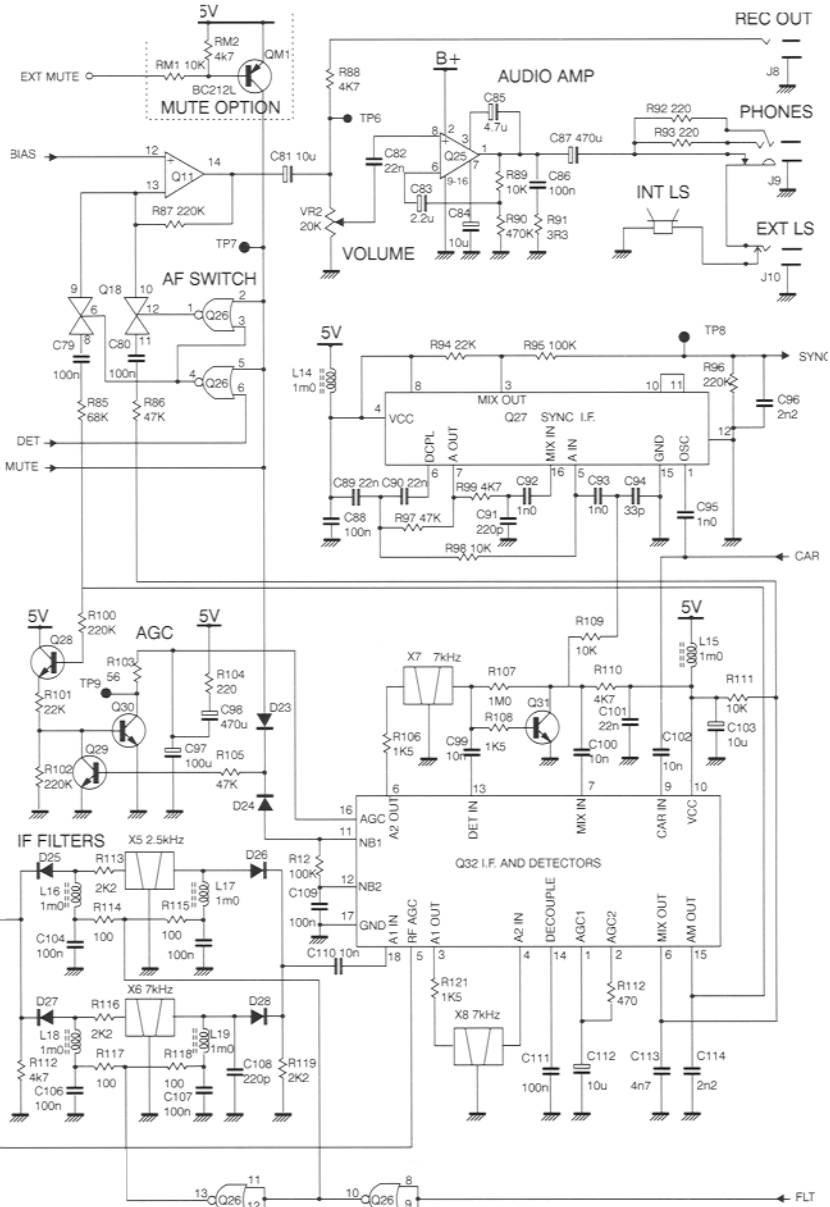

HF - 150 MAIN UNIT PLL SECTION

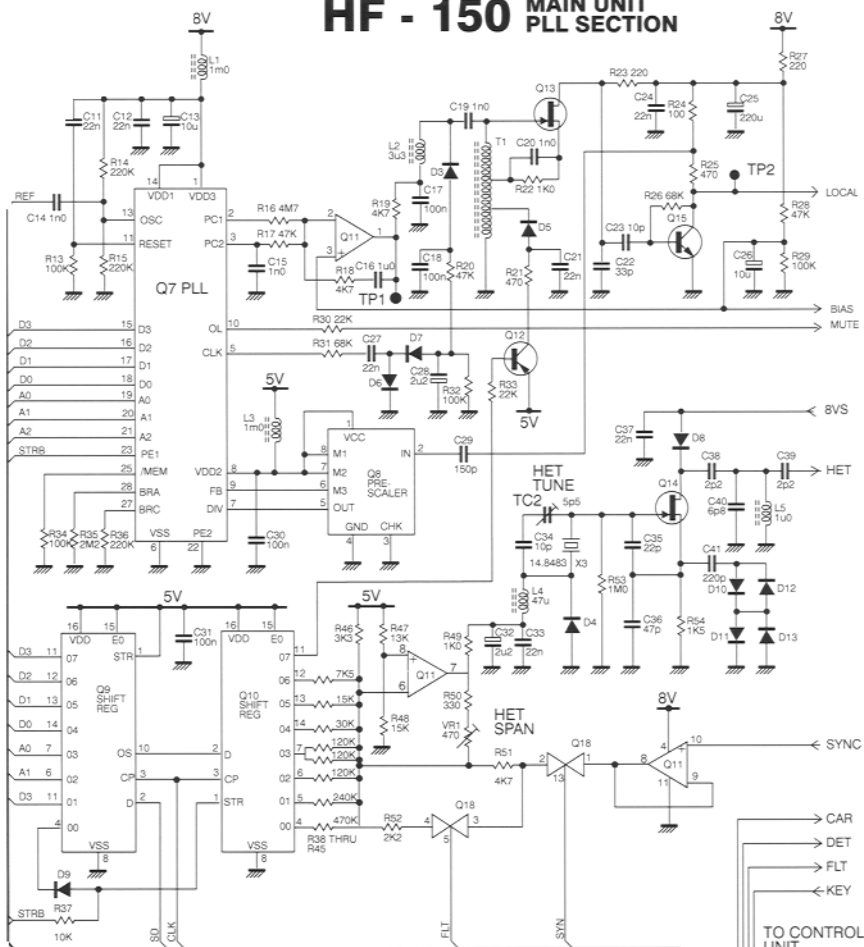

Q7	TDD1742T
Q8	uPB556C
Q9,10	74HC4094P
Q11	TL064CP
Q12	BC212L
Q13,14	J310
Q15	ZTX320
Q16	78L05
Q17	LP2951CM
Q18	CD4066P
D3,4	BB909A
D5	BA244A
D6-9	IN4148
D10-13	BAW62
D14-16	IN4002

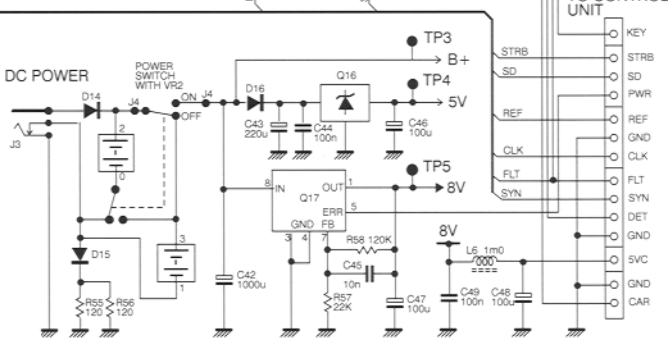

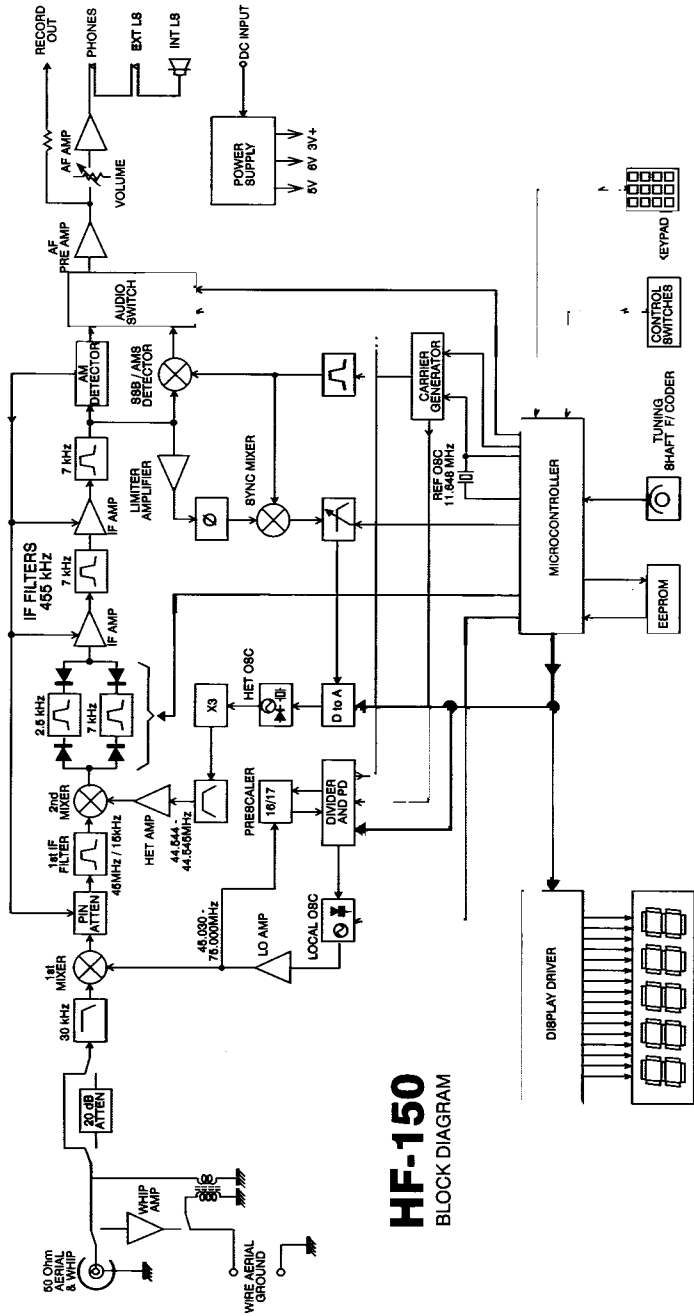

HF-150
BLOCK DIAGRAM

ACCESSORIES

PR-150

For added selectivity and rejection of unwanted signals



AP-150

Digital Audio Processor for enhanced audio output



KPAD-2

Keypad for ease of remote access to frequency and mode selection



IF-150

Computer RS232 Serial interface for ease of control and auto frequency selection



South Midlands Communications Ltd

S.M.House
School Close
Chandlers Ford Ind Est.
Eastleigh
Hampshire
SO53 4BY
U.K.

Tel: +44 (0)23 8024 6200

Fax: +44 (0)23 8024 6206

Email: sales@smc-comms.com

PR-150

ACCESSORIES