



COMMUNICATIONS EQUIPMENT/ANTENNA INNOVATIONS

KT-34XA

## KLM Tribander Update Kit

This Kit contains all parts and information necessary to update your older model KLM tribander to the latest dimensions, constructions, and performance.

IT IS IMPORTANT TO USE ALL THE NEW PARTS AND ALL THE DIMENSIONS SUPPLIED IN THE LATEST ASSEMBLY MANUAL (ATTACHED) OR PERFORMANCE AND SWR WILL BE DEGRADED. DISCARD YOUR OLD INSTRUCTIONS. READ THIS SHEET COMPLETELY BEFORE PROCEEDING.

### Parts List and Use:

3/4" O.D. x 23 3/4" ELEMENT TUBING (6) - Replace 20" tubing on REAR DRIVEN and DIRECTOR elements to meet new "D" Dimensions, (original 20" tubing on REFLECTOR and FRONT DRIVEN elements is of adequate length for re-adjustment).

3/8" O.D. x 8" CAPACITOR TUBES (6) - Replace 7 1/4" tubes on DIRECTOR and FRONT DRIVEN elements.

3/4" O.D. x 9" CAPACITOR TUBES (2) - Replace 7 1/4" tubes on REAR DRIVEN element.

CAPACITOR CAPS (40) - Replace all original capacitor caps. Do not mix! New soft caps are easier to install. Use steel wool on 3/8" tubing to remove oxidation and facilitate taking off old caps and sliding on new ones.

3/8" O.D. x 5" ELEMENT TIP TUBING/1/2" COMPRESSION CLAMPS/10-32 HARDWARE (2 ea.) - Use as needed to meet new "A" Dimension requirements. Install as outlined below:

1. Cut a 1" deep slit in both walls of the 1/2" tubing to be extended.
2. Prepare 1/2" clamp over the 1/2" tip tubing and insert 3/8" O.D. x 5" extension. Adjust to the "A" dimension PLUS 1/4" to electrically compensate for smaller tubing diameter. Tighten clamp. Repeat for other element half.

IMPORTANT CAPACITOR DRAIN/VENT MODIFICATION (ALL ELEMENTS) - Current KLM tribander capacitor sections have an internal venting/vacuum breaking system that virtually eliminates problems from atmospheric moisture and rain. Inside each 3/4" capacitor tube is a small hole through the upper wall of the 3/8" tube. IT IS IMPORTANT THAT OLDER MODEL TRIBANDERS HAVE THESE HOLES IN THE 3/8" TUBES AS THE NEW 3/4" CAPACITOR TUBES HAVE NO VENT OR DRAIN HOLES. The following steps outline how to drill the holes in the 3/8" tubing.

1. Steel wool the 3/8" tubing beyond the caps to facilitate removal and gain access to the capacitor area.

# KLM KT-34XA

COMMUNICATIONS EQUIPMENT/ANTENNA INNOVATIONS

## KT-34XA

The KT-34XA is the latest in KLM's new series of tribanders. Innovative in concept, practical in design, the KT-34XA outperforms all commercially available tribanders and many monoband systems, too.

The world famous, performance proven KT-34 is the heart of the "X". But, by doubling the boom length, adding one optimumly placed full size 10 meter element, and one more tri-resonant element, gain jumps by 4 dB on 10 meters and 2-2½ dB on 20 and 15.

Gain is virtually flat across 20 and 15 meters. On 10 meters, the "X" is optimized for the DX'er, 28 to 29 MHz.

While achieving performance equal to, or exceeding, a stacked monoband array, the modest size of the KT-34XA means smaller tower and rotator requirements and a lower overall windload.

Power handling capability is excellent and efficiency is high. Normal operation over the rated bandwidths require no adjustments other than assembly to the original instruction dimensions.

## SPECIFICATIONS

### Frequency of Operation:

20M: 14.0-14.350 MHz

15M: 21.0-21.450 MHz

10M: 28-29 MHz

### Gain:

20M: 8.5-9 dBd

15M: 9-9.5 dBd

10M: 11-11.3 dBd

F/B: 20 dB

F/S: 40 dB

Feed Impedance: 50 ohms unbalanced  
(with 4:1 balun supplied)

Power Rating: 4 KW PEP

### Active Elements:

20M = 5

15M = 5

10M = 6

Boom Length: 32'

Element Length: 25'8" Maximum

Turning Radius: 21'6"

Wind Area: app. 9 sq ft

Wind Survival: 100 MPH

Mounting: 2"O.D. mast

Boom Support: Overhead Guy Cables

Weight: 68 lbs.

Suitable Rotors: TR-44, Ham M type, HD-73 Alliance  
KR-400, etc.

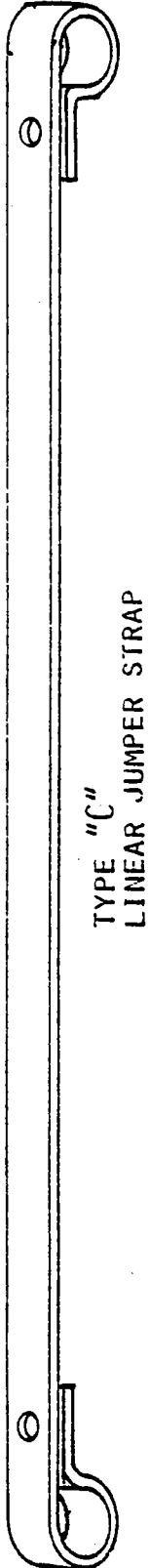

TYPE "C"  
LINEAR JUMPER STRAP

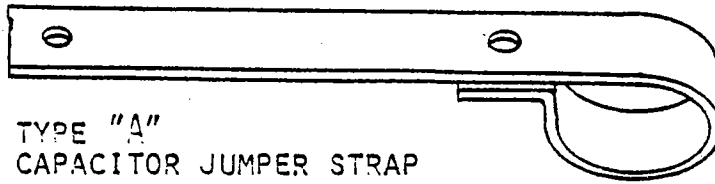

TYPE "A"  
CAPACITOR JUMPER STRAP

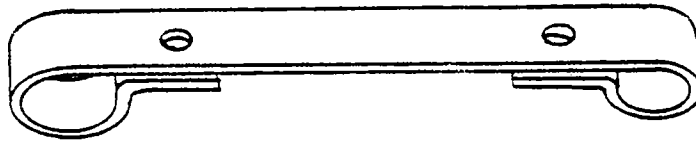

TYPE "B"  
15 METER SHORTING STRAP

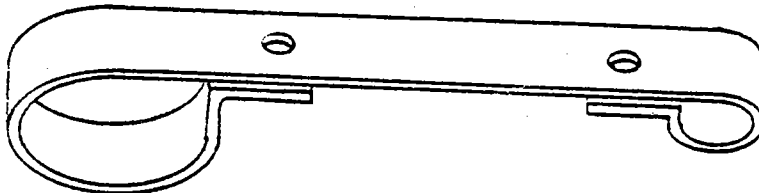

TYPE "D"  
MATCH STRAP

CAPACITOR  
CAPS

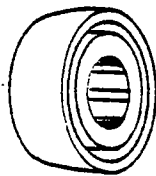

PHASING STRAP  
STANDOFF

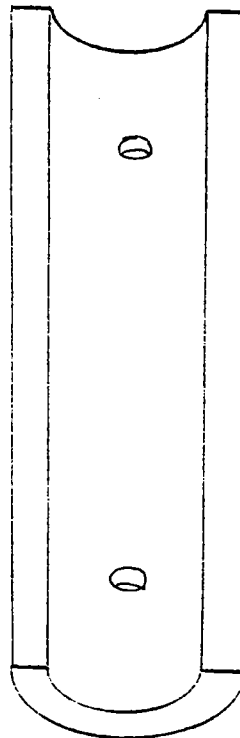
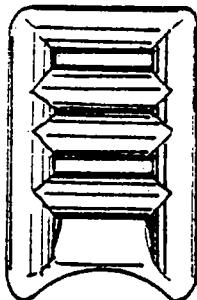

INSULATOR  
REDUCTION  
SECTION



LINEAR  
REINFORCING  
INSERT "PEANI"

LINEAR  
INSULATOR

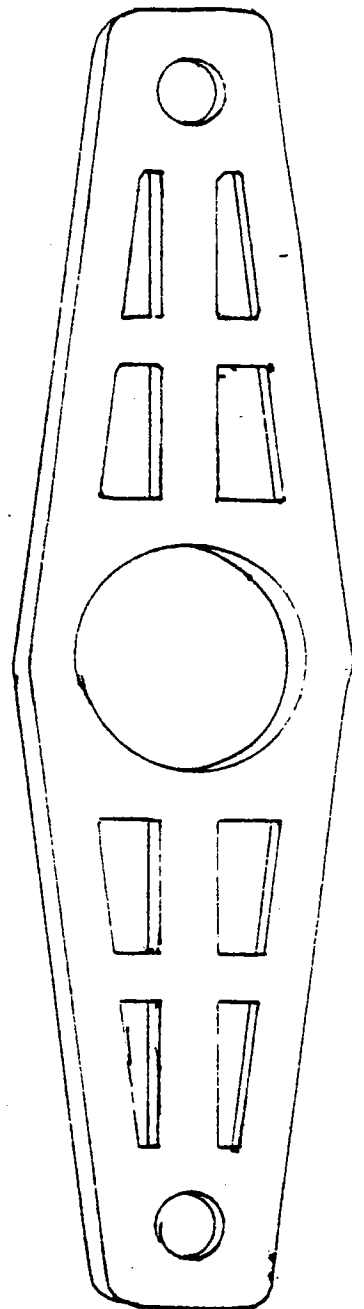

### III. CAPACITY BANK ASSEMBLY

NOTE: A short block of wood with a 7/16 to 1/2" hole, clamped in a bench vice is handy for use during installation of the plastic (polyethylene) capacitor caps.

The instructions make a special effort to show how to keep the position and orientation of element components consistent and symmetrical (among elements and element halves) during assembly. It is also helpful to refer often to the pictorials and the "Overview". You should identify various element sections with a feltpen as they are completed. This will speed assembly later.

The sketch below shows a typical pair of 3/8" O.D. linear loading sections with 3/4" O.D. capacitor tubes in place. Note the type "A" straps are installed on one section to form a mirror image of the other. This assures proper orientation when the complete element is assembled.

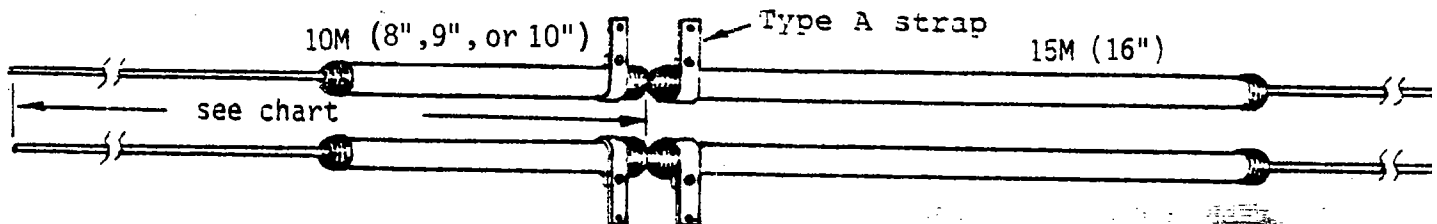

ELEMENT	3/8" O.D.	10M CAPACITOR	CENTER CAPS @	15M CAPACITOR
D3 Director	2 ea. 72"	8"	27"	16"
D1 Director	2 ea. 72"	8"	27 - 3/4"	16"
FD Front Driven	2 ea. 72"	8"	28"	16"
RD Rear Driven	2 ea. 77"	9"	28 1/2"	16"
R Reflector	2 ea. 77"	10"	28 - 3/4"	16"

- Each 3/8" x 72" and 77" tube has two vacuum-breaker holes drilled at 25" and 35" from one end. From this end, slide on two capacitor caps, back to back. Center the caps on the tubes according to the chart above. Lightly rounding tubing ends with fine sandpaper may help initial installation. Deburr vacuum breaker holes. For later assembly reference, make a mark away from the capacitor area to show the side of the tubing with the breaker holes (oriented "UP" in assembly).
- Prepare the 3/4" O.D. capacitor tubes for installation. Push a wad of cloth or foam through the inside of all tubes to remove aluminum chips, dust, moisture, etc. Capacitor sections: 3/4" O.D. x 8", 9", 10", and 16".
- Apply penetrox paste to all the capacitor tubes in the area shown in the sketch below. Then slide on the type "A" jumper straps until they are 1/4" from the end. Maintain mirror image positioning of straps in capacitor tube pairs. Install the 8-32 x 1/2" screw, lockwasher, and nut but do not tighten at this time.

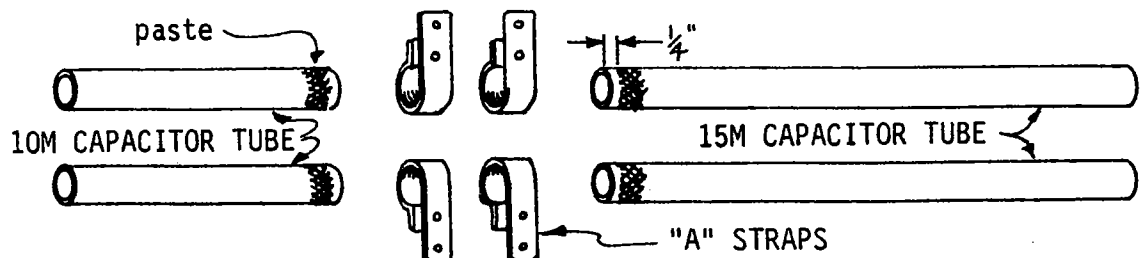

### IV. ELEMENT TIP ASSEMBLY (Reflector, Rear Driven, Front Driven, D1 & D3)

Study the sketch below before beginning.

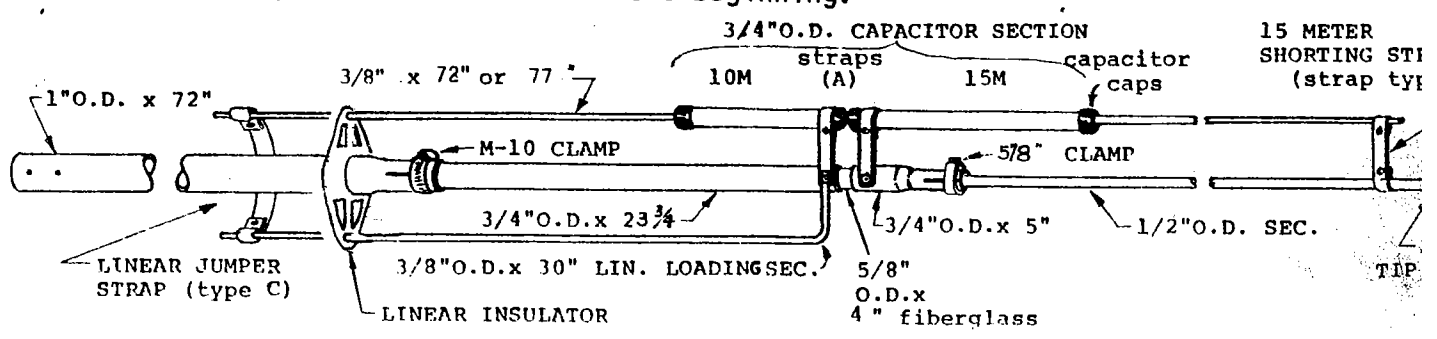

NOTE: A bench vice is handy for holding the 3/4 x 23-3/4 main part during this assembly.

1. Assemble the 3/4"O.D. x 23-3/4" (straight) and 5" (swaged) sections to opposite ends of the 5/8"O.D. x 4" fiberglass rods. Align holes and secure with 8-32 x 1 3/4" screws, nuts, and lockwashers. Tighten until the tubing flattens onto the rod and the assembly becomes rigid.

Repeat for all ten sections.

2. Bend all ten linear jumper straps to the arc drawn below. (Type "C" Jumper Strap)

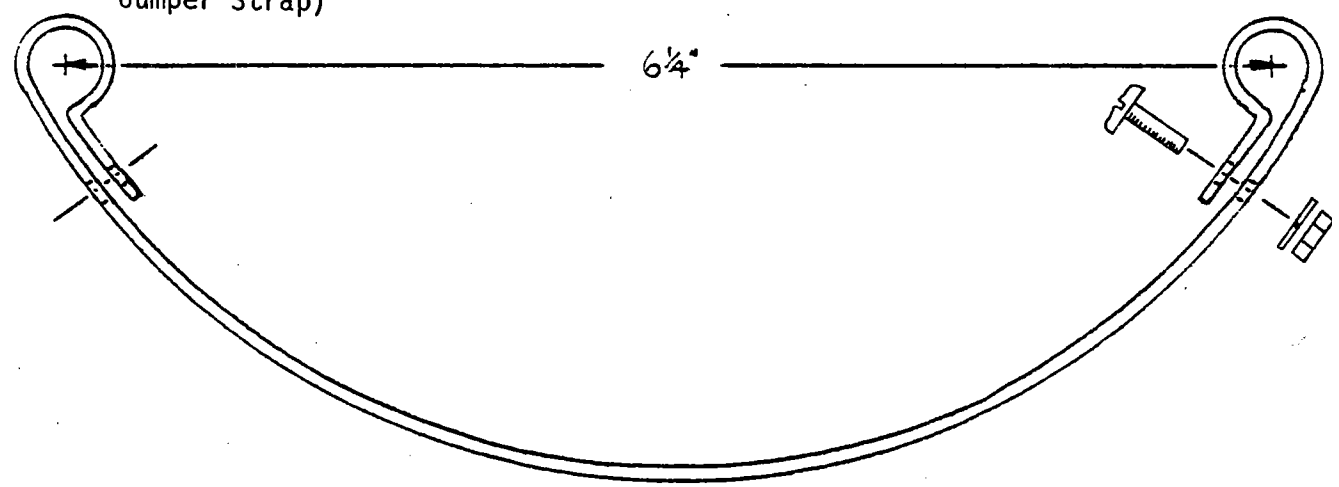

Add the 8-32 x 1/2" screws, nuts, & lockwashers. Finger tighten only at this time.

3. Prepare the type "B" shorting strap by adding the 8-32 x 1/2" screws, nuts, and lockwashers. Finger tighten only at this time.

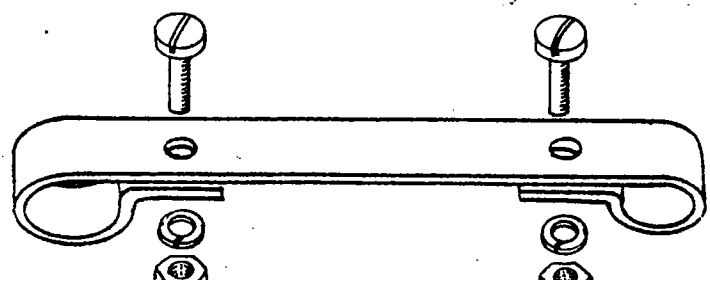

- Prepare ten 5/8" I.D. compression clamps as shown in sketch at right. Dab a bit of paste on the threads of the 10-32 x 3/8" hex-head screw. Position nut inside clamp channel and assemble.

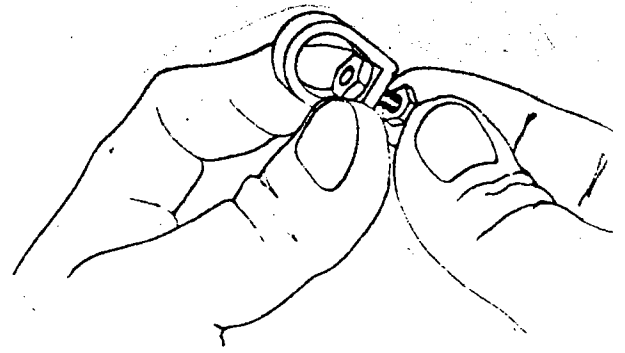

- Install the 1/2" O.D. element tip tubing to the central elements, starting with Director D3 element half.

Select the correct length from the chart below (D3 = 51"). Apply paste on the area to be inserted (about 3").

Place a 5/8" compression clamp on the swaged end of the 3/4" O.D. x 5" tube and insert the 1/2" tubing. Adjust for "A" dimension shown on chart below (D3 = 53"). To set, hook tape measure on the inside edge of the 15M A strap and measure to the outermost tip of the 1/2" tube (see sketch below). Tighten 5/8" compression clamp.

- Repeat step 12 for the other D3 element half and the remaining elements D1, FD, RD, and R.

	LENGTH OF 1/2" TUBING	"A"	DIMENSION "B"	"C"
D3 Director	51" (2)	53"	44"	26"
D1 Director	51" (2)	53-1/2"	43-1/2"	27"
FD Front Driven	41" (2)	43-3/4"	43"	26-3/4"
RD Rear Driven	51" (2)	53"	47-3/4"	27-1/4"
R Reflector	59" (2)	61-1/2"	47-1/2"	27-3/4"

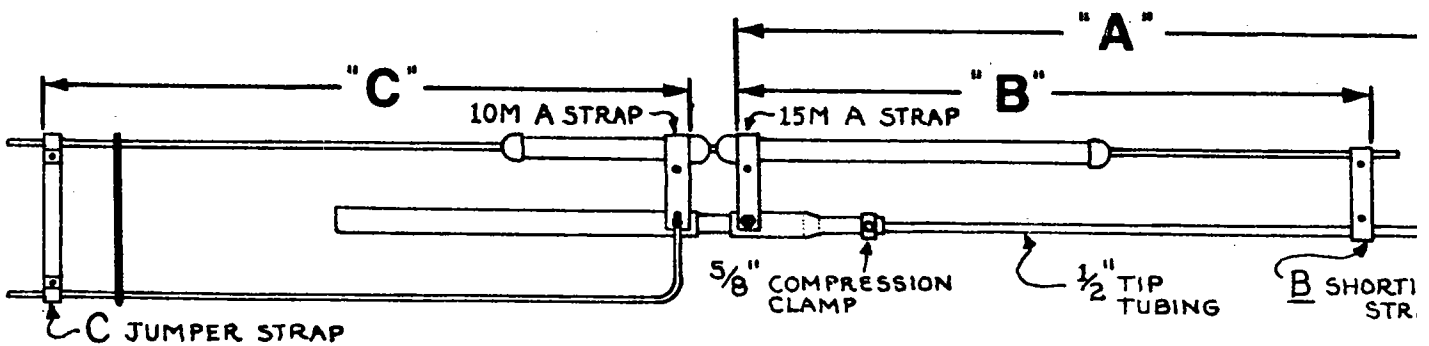

- Using a small swab, apply paste to the interior surface of all type B Shorting Strap and type C Jumper strap clamps (reference: page 8).
- Install the type B and Type C straps to the element assemblies, starting with Director D3 element.
- Install type B Shorting Strap between 1/2" tip tube and 3/8" linear loading tube and adjust for "B" dimension shown on chart above (D3 = 44"). To set, hook tape measure on the inside edge of the 15M A strap and measure to the outermost edge of the type B strap. Tighten strap screws.
- Install type C Jumper Strap to butt ends of 3/8" linear loading tubing. Orient so strap will hang under central element. Adjust for "C" dimension shown on chart above (D3 = 26"). To set, hook tape measure on 10M A strap and measure to outermost edge of type C strap. Tighten strap screws.
- Repeat steps 15 and 16 for other D3 element half, and for remaining elements D1, FD, RD, and R. Please note that tip caps are not supplied or recommended as they can capture water within elements

## VII. FRONT DRIVEN ELEMENT "T" MATCH ASSEMBLY

1. Locate the two type "D" match straps and install the  $\frac{1}{2}$ " x 8-32 screws, lockwash and nuts loosely.

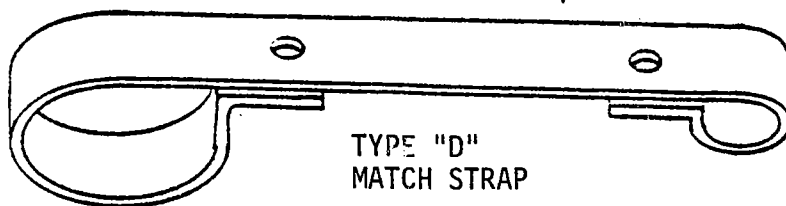

2. Select one of two remaining elements without center jumpers and slide a type "D" on each side locating them 18" each side of the element butts (apply paste under the straps).

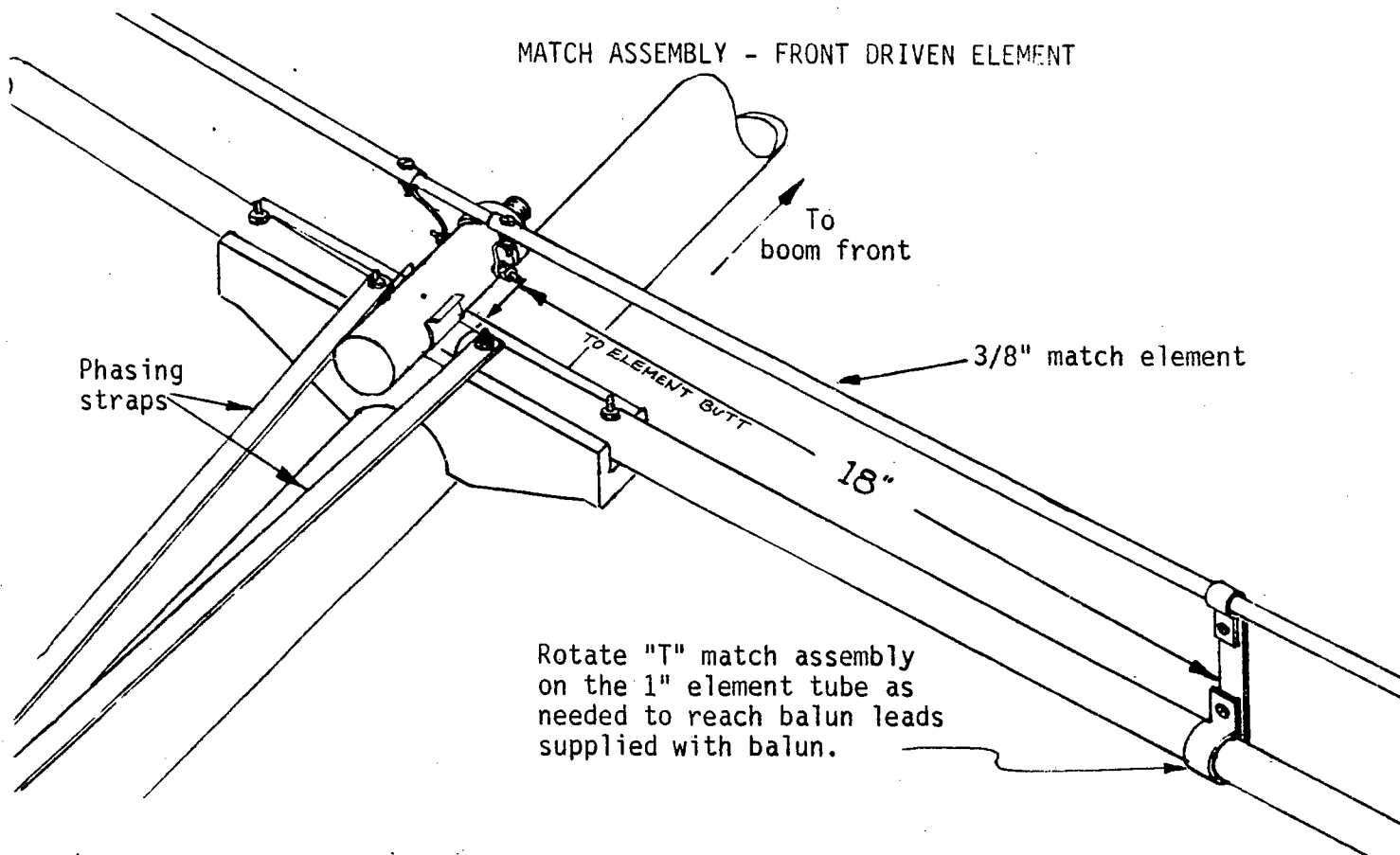

3. Now slide the preassembled  $\frac{3}{8}$ " O.D. match assembly tubing first into one side; then into the other. Apply paste to the appropriate areas under the strap. Center the assembly over the element insulator and tighten the type "D" strap screws.
4. Insert a #6 sheet metal screw through the end hole in the balun clip and mount the balun clip to the circular boss in the center of the element insulator.
5. Snap the 3-60-4:1 4KW PEP balun into place. Apply paste and attach the #12 AWG copper leads between the balun and the "T" match using #8 flatwashers, lockwashers, and nuts on the "T" match studs. Rotate "T" match ass'y off of vertical to make lead connections. DO NOT SUBSTITUTE LONGER LEADS.

NOTE: The only thing critical about this assembly is that paste is applied to all joints as this assembly carries the full power of your transmitter.

26 1/4

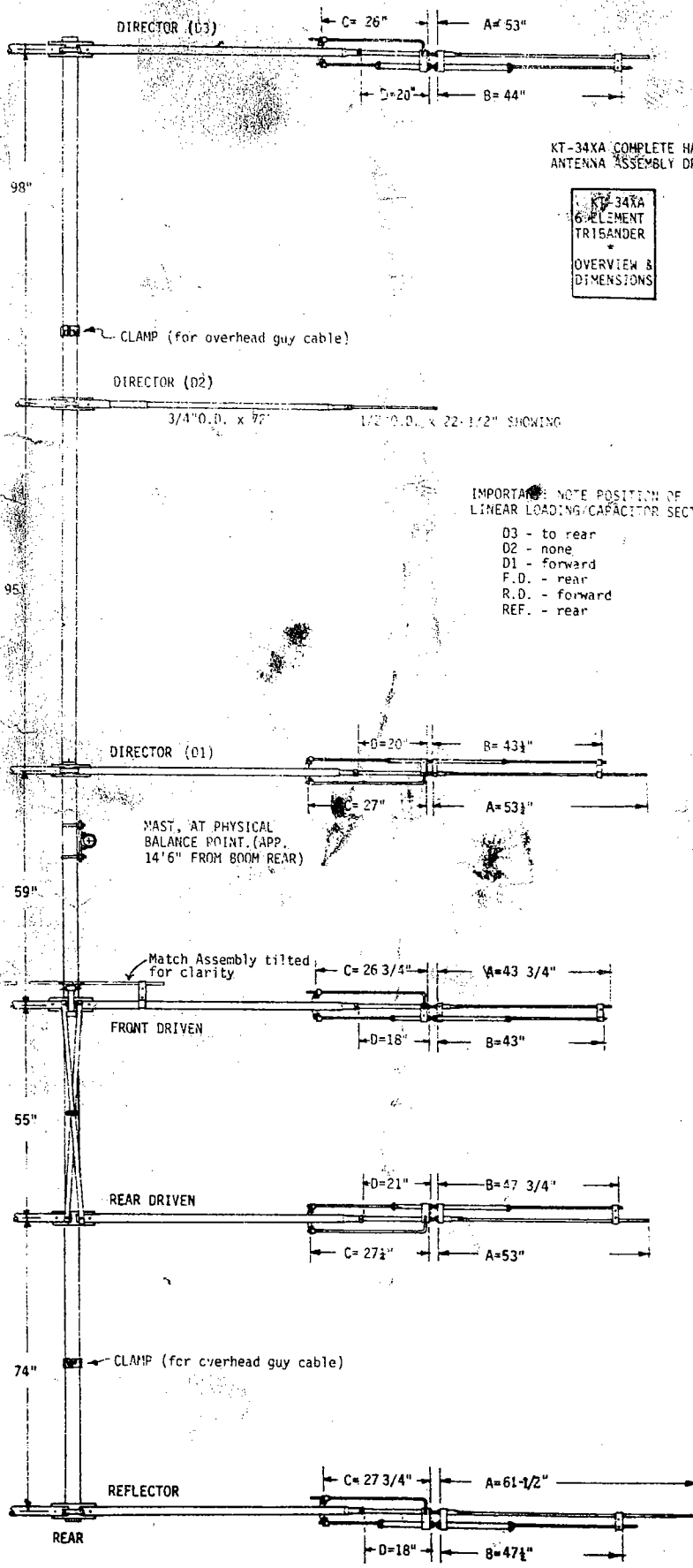

KT-34XA COMPLETE HALF ANTENNA ASSEMBLY DRAWING

KT-34XA  
6-ELEMENT  
TRIBANDER  
OVERVIEW &  
DIMENSIONS

IMPORTANT: NOTE POSITION OF LINEAR LOADING/CAPACITOR SECTIONS:

- D3 - to rear
- D2 - none
- D1 - forward
- F.D. - rear
- R.D. - forward
- REF. - rear

MAST, AT PHYSICAL BALANCE POINT. (APP. 14'6" FROM BOOM REAR)

Match Assembly tilted for clarity

REAR



## X. ELEMENT TIP MOUNTING

At this point, the size of your assembly area may dictate whether the element tips can be mounted now or the remainder of the assembly should be completed first. With some installations, the boom and partial elements may even be mounted to the tower before installing the element tip assemblies.

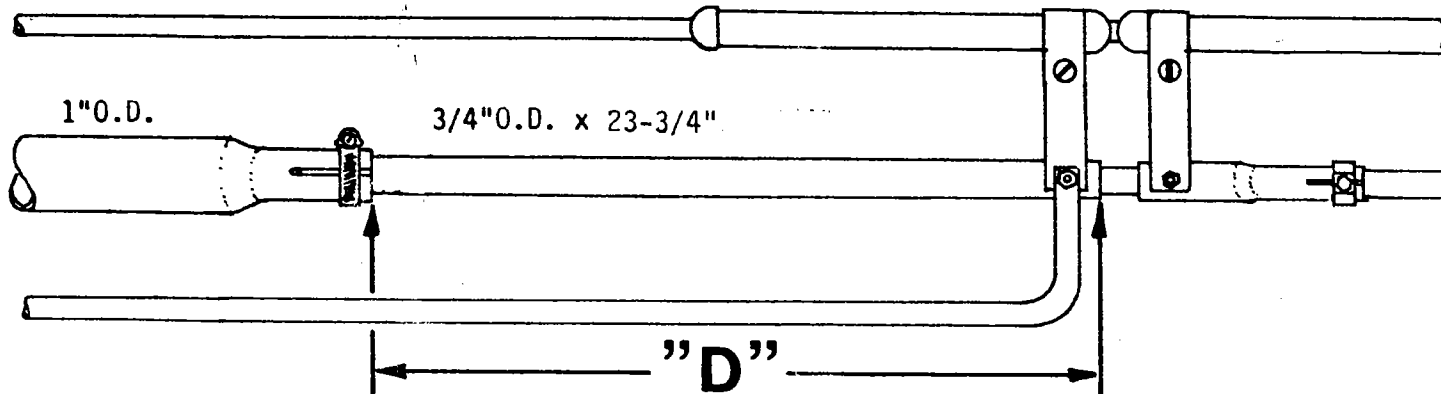

	"D" DIMENSION
DIRECTOR D3	20" showing
DIRECTOR D1	20" showing
FRONT DRIVEN	18" showing
REAR DRIVEN	21" showing
REFLECTOR	18" showing

1. Select the D3 tip assemblies. Refer to the "Antenna Overview" page for correct orientation of the capacitor sections. Also note that the capacitor straps/studs are "UP" and the vent holes (in the 3/8" tubing) are "UP".

Apply paste to about 3" of the butt of 3/4" x 23-3/4" tubing. Place an M-8/M-10 cap onto the swaged end of the 1" x 72" tubing. Insert the 3/4" tube into the swage until the correct "D" dimension is achieved (D3=20" - see chart at left). Tighten the band clamp.

Repeat for the other D3 tip assembly.

2. Repeat step 1 for D1, Front driven, Rear driven, and reflector elements. Use the "D" dimensions supplied on chart. Make sure the capacitor sections, straps, and studs are correctly oriented. Check marks on 3/8" tubing to be sure vent/vacuum-breaker holes are also oriented "up".

6. Prepare one end of each cable with a 2" loop using the KLM Lok-cubes as shown in the sketch below:

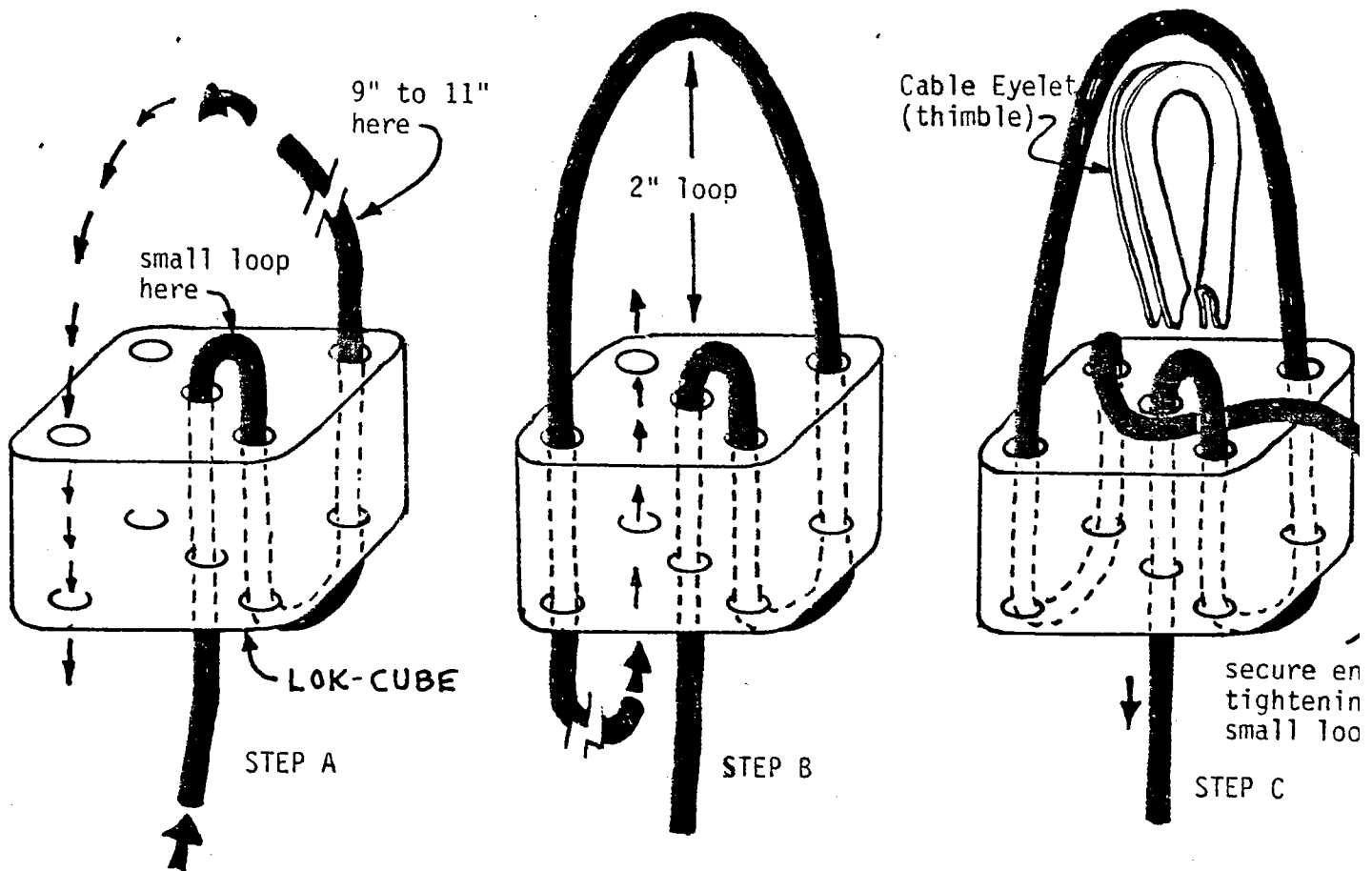

7. Place a cable eyelet (thimble) into each loop and snug up cables onto eyelets. Then install loop/eyelet into splits in each ring clamp. Secure with 3/8-16 x 2" bolts, lockwashers, and nuts.
8. Prepare the other end of each cable with Lok-cubes as far as step A only. Pull each cable taut and adjust until lok-cubes are about 2" to 3" from the turnbuckle eyebolts. Then thread the cable ends through the eyebolt and around the eyelets. Complete rigging as shown in steps B and C, snugging up cables on the eyelets. Balance tension on mast so it is not pulled to front or rear., but remains vertical.
9. Make further rough boom straightening adjustments by moving the ring clamps on the boom. When finished, disconnect harness center plate and remove temporary mast. Secure loose cables to boom so they do not interfere during installation.
10. After the antenna is installed on permanent mast, reattach center plate with 2" U-bolt, raising or lowering as needed to keep boom straight. The guy rigging usually stretches very slightly as it takes it's "set" and you may want to compensate for that, particularly if the antenna is not easily accessible. Otherwise, minor straightening and tension balancing adjustments are accomplished with the two turnbuckles. Block eyebolts during adjustment so cables are not twisted. When finished, safety wire the turnbuckles so they cannot unwind.

## FINAL INSTALLATION AND CHECKOUT

1. When installing antenna, remember to allow about 2½ feet of mast above the boom for mounting the guy harness center plate.
2. After antenna is installed, reconnect center plate and slide it up mast until the boom is straight. Final adjustments and balancing of tension are accomplished adjusting turnbuckles. Block the eyebolts to prevent twisting of cables during adjustment. When boom is straight, safety-wire the turnbuckles.
3. See Page 18 for typical SWR curves for each band. Your curves may vary somewhat due to instrument accuracy, height above ground, surrounding objects, etc. But, you should be able to recognize key corner points and ripple.

## INSTALLATION HINTS AND KINKS

1. Good quality coax feedline of the proper impedance is a major factor in achieving good VSWR across each ham band. KLM recommends the following cable.

1. RG-213 AU
2. Times FM-8 Foam Coax
3. Belden 8214 Foam Coax

Other brands of foam "RG-8 type" coax are typically not 50 ohm (more like 60-70 ohm) and should be avoided.

2. Large objects and other antennas, 40 or 80 meter dipoles for instance, can also affect the VSWR of a tribander. To check for detrimental effects, temporarily lower or remove the dipole or at least rotate it 90° out of line with the tribander elements. If the VSWR is reduced, one of the antennas should be relocated to avoid adversely affecting the performance of the Tribander.

The KLM 40 meter dipole (7.2-1) can be used with the Tribander and will work well. But, the dipole must be mounted above or below the Tribander and in line with its boom (90° out from elements).

3. Mounting height: Generally, the comment "the higher - the better" is true. Excellent performance can be realized, however, from 30 feet on up. Ten (10) meters will be affected least by increased heights over 30 feet and 20 meters will be improved the most.

Overall, antenna efficiency is reduced at low heights because surrounding objects (building, trees, metal fences, etc.) absorb RF from the antenna before that energy can become a sky-wave. Whenever possible, mount the antenna high and in the clear.

KT-34XA TYPICAL VSWR CURVES

